

Table of Contents







Overview	2
25 ml Cartridge	4
50 ml and 75 ml Cartridge	6

MIXPAC™ B-System Overview

25/50/75mL Industrial Set

ACCESSORIES



Accessories

	ID	Article
	101651	BRT 205-10
	102274	IOT 406-15
	102277	IOT 506-15
	129178	IOT 715-50
	102356	LA 05-00
	102357	LA 06-08

Outlet Tip

-  Tapered Tip (S)
-  Straight Tip (D)
-  Luer Slip Tip (L)
-  Stepped Tip (T)

MIXER

-  ○ MBH (Helix)
-  ● MBQ (Quadro)

25mL

50mL

CARTRIDGE

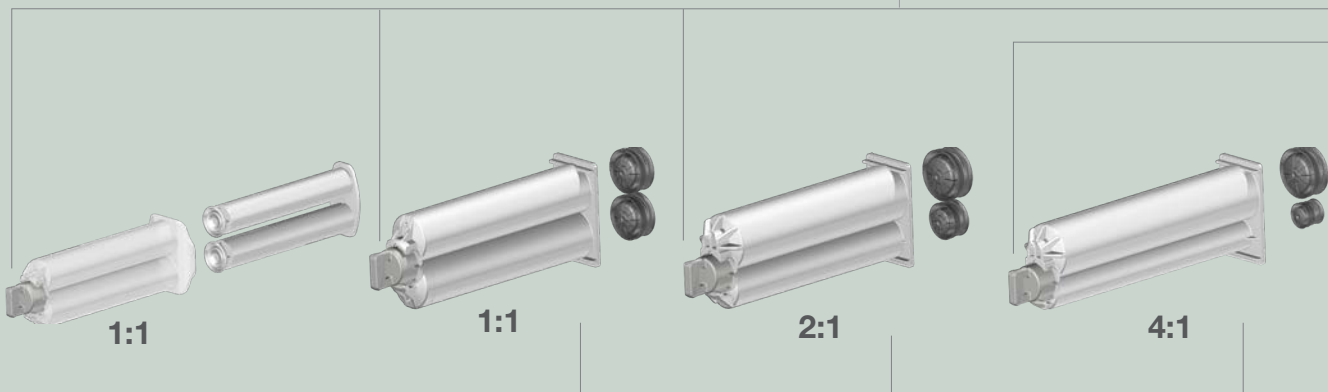

DISPENSER





Interface Converter

B-System => K-System

Ratio	ID	Article
1:1/2:1	128201	IBK 001-10
4:1/10:1	128202	IBKX 001-10



Interface Mixer

K-System

Ratio	Article
1:1/2:1	MKH
4:1/10:1	MKHX

=> for further information see K-System

Piston Retention Plate



Ratio	ID	Article
1:1/2:1	113719	PRS 050-01-02
4:1/10:1	116564	PRS 050-04-10A



- MBHX (Helix)
- MBQX (Quadro)

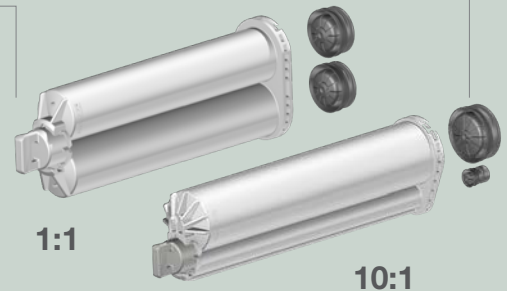
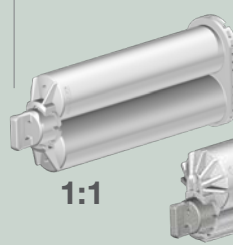
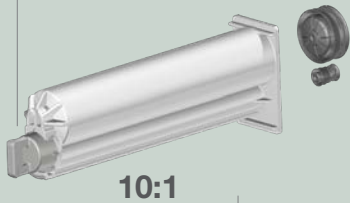

BS flange



MIXPAC™ B-System Cartridge Set

25 Industrial Set Cartridge Assembly 25mL

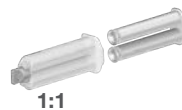

Ratio Set/ Volume	ID	Article	Cartridges Material/Color	Plunger	Units/ Box	Mixer Technology
1:1 25mL	116647	AB 025-01-10-01	PP/ Ⓝ	Ⓝ	1000	MBH ○ MBQ ●
	116924	AB 025-01-10-02	PP/ Ⓝ	●	1000	MBH ○ MBQ ●
	116926	AB 025-01-10-05	PP/ Ⓝ	●	1000	MBH ○ MBQ ●
	116927	AB 025-01-10-07	PP/ ●	●	1000	MBH ○ MBQ ●
	128982	AB 025-01-10-08	PP/ ●	●	1000	MBH ○ MBQ ●
	116649	AB 025-01-30-01	PA/ Ⓝ	Ⓝ	1000	MBH ○ MBQ ●
	116923	AB 025-01-30-07	PA/ ●	●	1000	MBH ○ MBQ ●
	129377	AB 025-01-30-09	PA/ ●	●	1000	MBH ○ MBQ ●

MIXPAC™ B-System Cartridge Set

50/75 Industrial Set Cartridge Assembly 50/75mL







Ratio Set/ Volume	ID	Article	Cartridges Material/ Color	Piston Type/ Material	O-ring	Units/ Box	Mixer Technology	Matching Dispenser
1:1 50mL	112511	AB 050-01-10-01	PP/ ○	PP, self-venting	-	1250	MBH ○ MBQ ●	DMA ● DP ●
	116347	AB 050-01-10-02	PP/ ○	PP, self-venting	EPDM	1250	MBH ○ MBQ ●	DMA ● DP ●
	128082	AB 050-01-10-05	PP/ ○	PP, self-venting	Silicone	1250	MBH ○ MBQ ●	DMA ● DP ●
	154853	AB 050-01-10-33	PP/ ○	HDPE, self-venting	-	1250	MBH ○ MBQ ●	DMA ● DP ●
	154825	AB 050-01-10-34	PP/ ○	HDPE, self-venting	EPDM	1250	MBH ○ MBQ ●	DMA ● DP ●
	154854	AB 050-01-10-37	PP/ ●	HDPE, self-venting	-	1250	MBH ○ MBQ ●	DMA ● DP ●
	117031	AB 050-01-20-01	PBT/ (N)	PA, self-venting	-	1250	MBH ○ MBQ ●	DMA ● DP ●
	128335	AB 050-01-20-02	PBT/ (N)	PA, self-venting	EPDM	1250	MBH ○ MBQ ●	DMA ● DP ●
	154855	AB 050-01-20-33	PBT/ (N)	HDPE, self-venting	-	1250	MBH ○ MBQ ●	DMA ● DP ●
	154824	AB 050-01-20-34	PBT/ (N)	HDPE, self-venting	EPDM	1250	MBH ○ MBQ ●	DMA ● DP ●
	154857	AB 050-01-30-33	PA/ ○	HDPE, self-venting	-	1250	MBH ○ MBQ ●	DMA ● DP ●
	154485	AB 050-01-30-34	PA/ ○	HDPE, self-venting	EDPM	1250	MBH ○ MBQ ●	DMA ● DP ●
	154851	AB 050-01-30-37	PA/ ●	HDPE, self-venting	-	1250	MBH ○ MBQ ●	DMA ● DP ●
	2:1	114099	AB 050-02-10-01	PP/ ○	PP, self-venting	-	1250	MBH ○ MBQ ●
116342		AB 050-02-10-02	PP/ ○	PP, self-venting	EPDM	1250	MBH ○ MBQ ●	DMA ● DP ●
154645		AB 050-02-10-33	PP/ ○	HDPE, self-venting	-	1250	MBH ○ MBQ ●	DMA ● DP ●
154646		AB 050-02-10-34	PA/ ○	HDPE, self-venting	EPDM	1250	MBH ○ MBQ ●	DMA ● DP ●
116354		AB 050-02-30-01	PA/ ○	PA, self-venting	-	1250	MBH ○ MBQ ●	DMA ● DP ●
116356		AB 050-02-30-02	PA/ ○	PA, self-venting	EPDM	1250	MBH ○ MBQ ●	DMA ● DP ●
128346		AB 050-02-30-03	PA/ (N)	PA, self-venting	-	1250	MBH ○ MBQ ●	DMA ● DP ●
154676		AB 050-02-30-33	PP/ ○	HDPE, self-venting	-	1250	MBH ○ MBQ ●	DMA ● DP ●
154705		AB 050-02-30-34	PA/ ○	HDPE, self-venting	EPDM	1250	MBH ○ MBQ ●	DMA ● DP ●
154707		AB 050-02-30-35	PA/ (N)	HDPE, self-venting	-	1250	MBH ○ MBQ ●	DMA ● DP ●
4:1 50mL	116421	AB 050-04-10-01	PP/ ○	A-piston, PP, self-venting lip seal; B-piston, PP, solid lip seal	-	625	MBHX ● MBQX ●	DMB ● DP ●
	128606	AB 050-04-10-02	PP/ ○	A-piston, PP, self-venting lip seal; B-piston, PP, solid lip seal with O-ring	EPDM	625	MBHX ● MBQX ●	DMB ● DP ●
	116422	AB 050-04-20-01	PBT/ (N)	A-piston, PA, self-venting lip seal; B-piston, PA, solid lip seal	-	625	MBHX ● MBQX ●	DMB ● DP ●
10:1 50mL	116423	AB 050-10-10-01	PP/ ○	A-piston, PP, self-venting lip seal; B-piston, PP, solid lip seal	-	625	MBHX ● MBQX ●	DMB ● DP ●
	151982	AB 050-10-10-02	PP/ ○	A-piston, PA, self-venting lip seal; B-piston, HDPE, solid piston with O-ring	EDPM	625	MBHX ● MBQX ●	DMB ● DP ●
	116424	AB 050-10-20-01	PBT/ (N)	A-piston, PA, self-venting lip seal; B-piston, PA, solid lip seal	-	625	MBHX ● MBQX ●	DMB ● DP ●

BS flange



Ratio Set/ Volume	ID	Article	Cartridges Material/ Color	Piston Type/ Material	O-ring	Units/ Box	Mixer Technology	Matching Dispenser
1:1 50mL	154850	AB S50-01-10-33	PP/ ○	HDPE, self-venting	-	1250	MBH ● MBQ ○	DS ● DP ●
	154829	AB S50-01-10-37	PP/ ●	HDPE, self-venting	-	1250	MBHX ● MBQX ●	DS ● DP ●
	154828	AB S50-01-30-33	PA/ ○	HDPE, self-venting	-	1250	MBH ● MBQ ○	DS ● DP ●
75mL	128619	AB S75-01-10-01	PP/ ⊗	PP, self-venting	-	625	MBHX ● MBQX ●	DS ● DP ●
	158029	AB S75-01-10-33	PP/ ⊗	HDPE, self-venting	-	625	MBHX ● MBQX ●	DS ● DP ●
2:1 50mL	154708	AB S50-02-10-33	PP/ ○	HDPE, self-venting	-	1250	MBHX ● MBQX ●	DS ● DP ●
10:1 50mL	152458	AB S50-10-10-01	PP/ ○	PP, self-venting	-	625	MBHX ● MBQX ●	DS ● DP ●
	116373	AB S50-10-20-01	PBT/ ⊗	PA, self-venting	-	1250	MBHX ● MBQX ●	DS ● DP ●
	116805	AB S50-10-20-06	PBT/ ⊗	PA, solid lip seal with O-ring	Silicone	1250	MBHX ● MBQX ●	DS ● DP ●
	152397	AB S50-10-20-08	PBT/ ⊗	A-piston, PA, self-venting lip seal B-piston, PA, solid lip seal with O-ring	Silicone	1250	MBHX ● MBQX ●	DS ● DP ●
10:1 75mL	116449	AB S75-10-20-02	PBT/ ⊗	PA, solid lip seal with O-ring	Silicone	900	MBHX ● MBQX ●	DS ● DP ●
	116305	AB S75-10-20-03	PBT/ ⊗	PA, solid lip seal with O-ring	Silicone	350	MBHX ● MBQX ●	DS ● DP ●
	154086	AB S75-10-20-05	PBT/ ⊗	A-piston, PA, self-venting lip seal B-piston, PA, self-venting lip seal with O-ring	Silicone	900	MBHX ● MBQX ●	DS ● DP ●

Matching mixers

	ID	Article	Number of Elements	Inner Diameter Ø mm/inch	Waste Volume (mL)	Units/ Box	Outlet Tip				Accessories					
							Stepped Tip (T)	Straight Tip (D)	Luer Slip Tip (L)	Tapered Tip (S)	LA 05-00	LA 06-08	BRT 205-10	IOT 406-15	IOT 506-15	IOT 212-20
1:1/2:1 MBH	116457	MBH 03-12D	12	3.2/0.126	0.49	8000	✓						✓	✓	✓	
	116458	MBH 03-12S	12	3.2/0.126	0.49	8000			✓							
	116459	MBH 03-16D	16	3.2/0.126	0.63	8000	✓						✓	✓	✓	
	116460	MBH 03-16L	16	3.2/0.126	0.63	7000			✓							
	116461	MBH 03-16S	16	3.2/0.126	0.59	8000				✓						
	 116462	MBH 04-12D	12	4.2/0.165	0.84	7000	✓							✓		
	116463	MBH 04-16D	16	4.2/0.165	1.04	5000	✓							✓		
	116464	MBH 04-16S	16	4.2/0.165	1.04	5000				✓						
	116575	MBH 05-06T	6	5.4/0.213	0.94	8000	✓			✓						
	116465	MBH 05-12D	12	5.4/0.213	1.52	5000		✓					✓	✓		
	116466	MBH 05-14D	14	5.4/0.213	1.91	4000		✓					✓	✓		
	116467	MBH 05-16T	16	5.4/0.213	1.91	4000	✓			✓						
	116468	MBH 05-20T	20	5.4/0.213	2.29	3000	✓			✓						
	116469	MBH 06-11D	11	6.5/0.256	2.28	4000		✓					✓	✓		
	116470	MBH 06-16T	16	6.5/0.256	3.14	3000	✓						✓			
	116471	MBH 06-20T	20	6.5/0.256	3.76	2000	✓						✓			✓
	116472	MBH 07-11D	11	7.5/0.295	3.05	4000		✓								
4:1/10:1 MBHX	116473	MBHX 03-16S	16	3.2/0.126	0.60	7000			✓							
	116474	MBHX 04-16D	16	4.2/0.165	1.05	6000	✓						✓			
	116576	MBHX 04-16S	16	4.2/0.165	1.05	5000			✓							
	116475	MBHX 05-12D	12	5.4/0.213	1.52	5000		✓					✓	✓	✓	
	116476	MBHX 05-16T	16	5.4/0.213	1.91	4000	✓			✓						
	 116477	MBHX 05-20T	20	5.4/0.213	2.07	3000	✓			✓						
	116478	MBHX 06-16D	16	6.5/0.256	3.14	3000		✓					✓			
	116480	MBHX 06-16T	16	6.5/0.256	3.04	3000		✓					✓	✓		
116481	MBHX 06-20T	20	6.5/0.256	3.79	2000	✓						✓				
1:1/2:1 MBQ	114144	MBQ 05-16L	16	5.3/0.209	1.88	3000			✓							
	154801	MBQ 05-16L-12 ●*	16	5.3/0.209	1.88	3000			✓							
	 114145	MBQ 05-24L	24	5.3/0.209	2.60	3000			✓							
4:1/10:1 MBQX	116063	MBQX 05-16L	16	5.3/0.209	1.72	3000			✓							
	 116062	MBQX 05-24L	24	5.3/0.209	2.37	3000			✓							

* different color

Matching dispensers

	ID	Article	Flange		Ratio				Force (kN)
			B 50	B S50	1:1	2:1	4:1	10:1	
DMA/DMB dispenser manual 	101875	DMA 51-00-10	✓		✓	✓			1.2
	116795	DMB 50-04-01	✓				✓		1.2
	116794	DMB 50-10-01	✓					✓	1.2
DS dispenser manual 	101934	DS 53-01-00		✓	✓	✓			1.2
	109146	DS 51-04-00		✓			✓		1.2
	101929	DS 51-10-00		✓				✓	1.2
	115676	DS 75-10-00		✓				✓	1.2
	110938	DS 77-01-00		✓	✓				1.2
DP dispenser pneumatic 	151780	DP2 50-16-100	✓		✓	✓			1.6
	153094	DP2 50-16-400	✓				✓	✓	1.6
	151886	DP2 50-16-300		✓				✓	1.6
	151781	DP2 50-16-200		✓	✓	✓			1.6